

10/30

**HERITAGE TRACTOR
CODE 133E**

ILLUSTRATED PARTS LIST

CODE SERIAL NO.
133E 470000001
ISSUE 01/23/2007
1740517

PART NO: 111-1179 (Rev A)

PRODUCT COMPONENTS	PAGES
Chassis & Hood	4
Steering	8
Motion Drive	10
Mower Housing	14
Mower Housing Suspension	18
Decals	20
Electrical System	22
Torque Specification Chart	Inside Back Cover

Chassis & Hood

0003

NOTE: Unless noted otherwise,
use the standard hardware torque
specification chart.

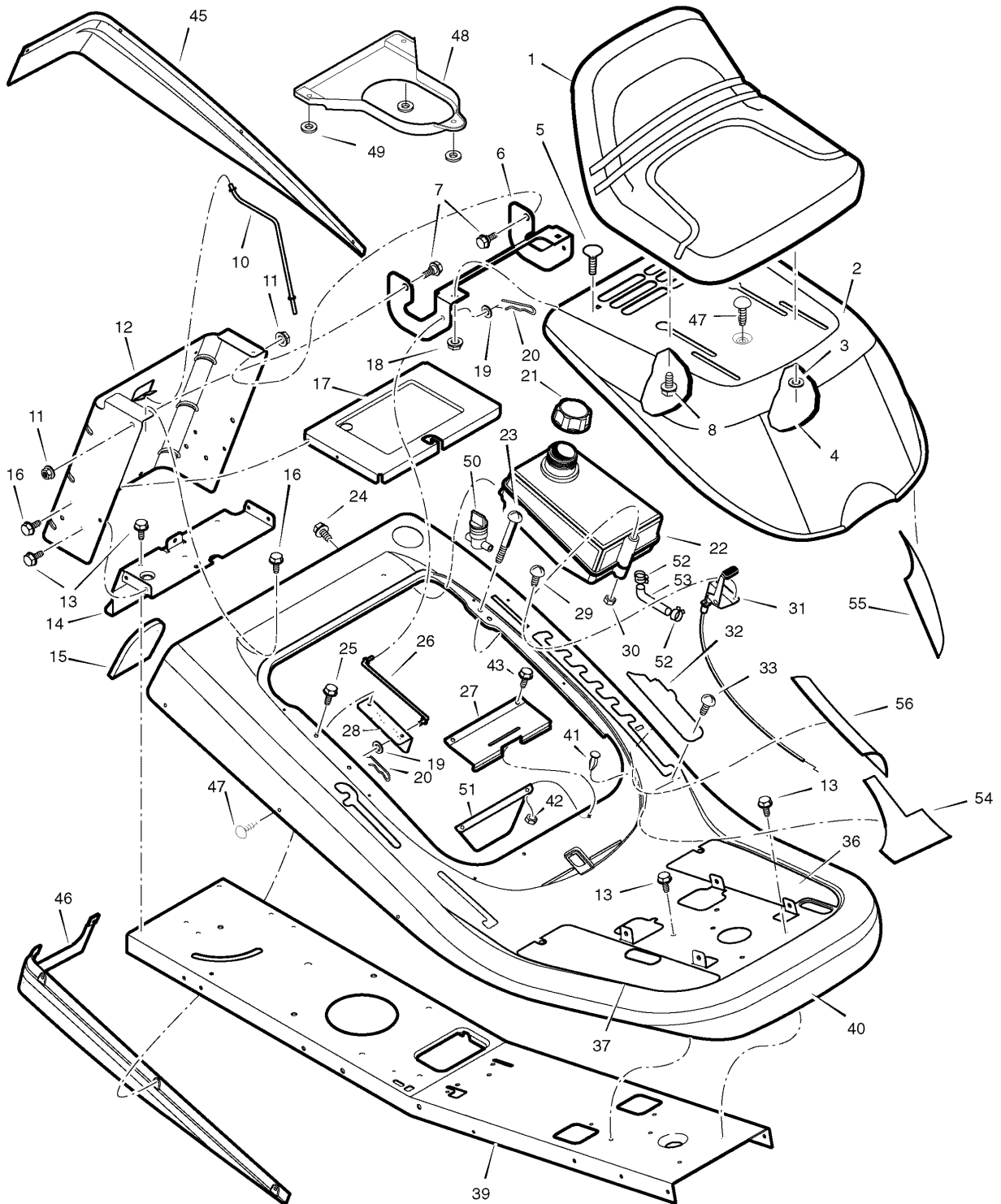

The above parts group applies to the following Mfg. Nos.:
309029x11E - 10/30, Heritage Tractor (2007)

Chassis & Hood

REF NO	PART NO.	DESCRIPTION
1	MU690566MA	Seat
2	MU1401379E549MA	Hood
3	MU017X47MA	Washer
4	MU1001054MA	Bolt, Wing
5	MU002X16MA	Bolt, Carriage
6	MU1401378E701MA	Bracket, Hinge
7	MU009X29MA	Bolt, Shoulder
8	MU009X56MA	Bolt, Shoulder
10	MU1401113MA	Rod, Battery
11	MU015X84MA	Nut, Flange
12	MU1401025E701MA	Plate, Rear
13	MU26X249MA	Screw
14	MU1401050E701MA	Plate, Hitch
15	MU1401087MA	Cover
16	MU26X263MA	Screw
17	MU1401076E701MA	Tray, Battery
18	MU015X79MA	Nut, Flange
19	MU017X45MA	Washer
20	MU0031X6MA	Pin, Cotter
21	MU092317MA	Cap, Fuel Tank (Included when ordering Ref. No. 22)
22	MU1401361MA	Tank, Fuel
23	MU06X111MA	Screw (Included when ordering Ref. No. 22)
24	MU26X253MA	Screw
25	MU26X263MA	Screw
26	MU1401110MA	Rod, Hood Prop
27	MU1401282MA	Spring, Seat Deck
28	MU1401297E701MA	Bracket, Prop Rod
29	MU26X201MA	Screw
30	MU15X116MA	Nut, NY-Lock
31	MU1401248MA	Control, Throttle
32	MU1401084MA	Cover, Detent (Black)
33	MU009X47MA	Bolt, Shoulder
36	MU1401229MA	Footmat, Left (Black)
37	MU1401228MA	Footmat, Right (Black)
39	MU1401371E701MA	Frame
40	MU1401349E549MA	Deck, Seat
41	MU094744MA	Bumper
42	MU15X116MA	Nut (Included when ordering Ref. No. 22)
43	MU0025X2MA	Screw
44	MU7601036MA	Kit, Foil Heat Shield
45	MU1401076MA	Trim, Left
46	MU1401072MA	Trim, Right
47	MU0196X1MA	Fastener, Panel
48	MU1401380MA	Plenum

Footnotes

The above parts group applies to the following Mfg. Nos.:

309029x11E - 10/30, Heritage Tractor (2007)

Chassis & Hood

0003

NOTE: Unless noted otherwise,
use the standard hardware torque
specification chart.

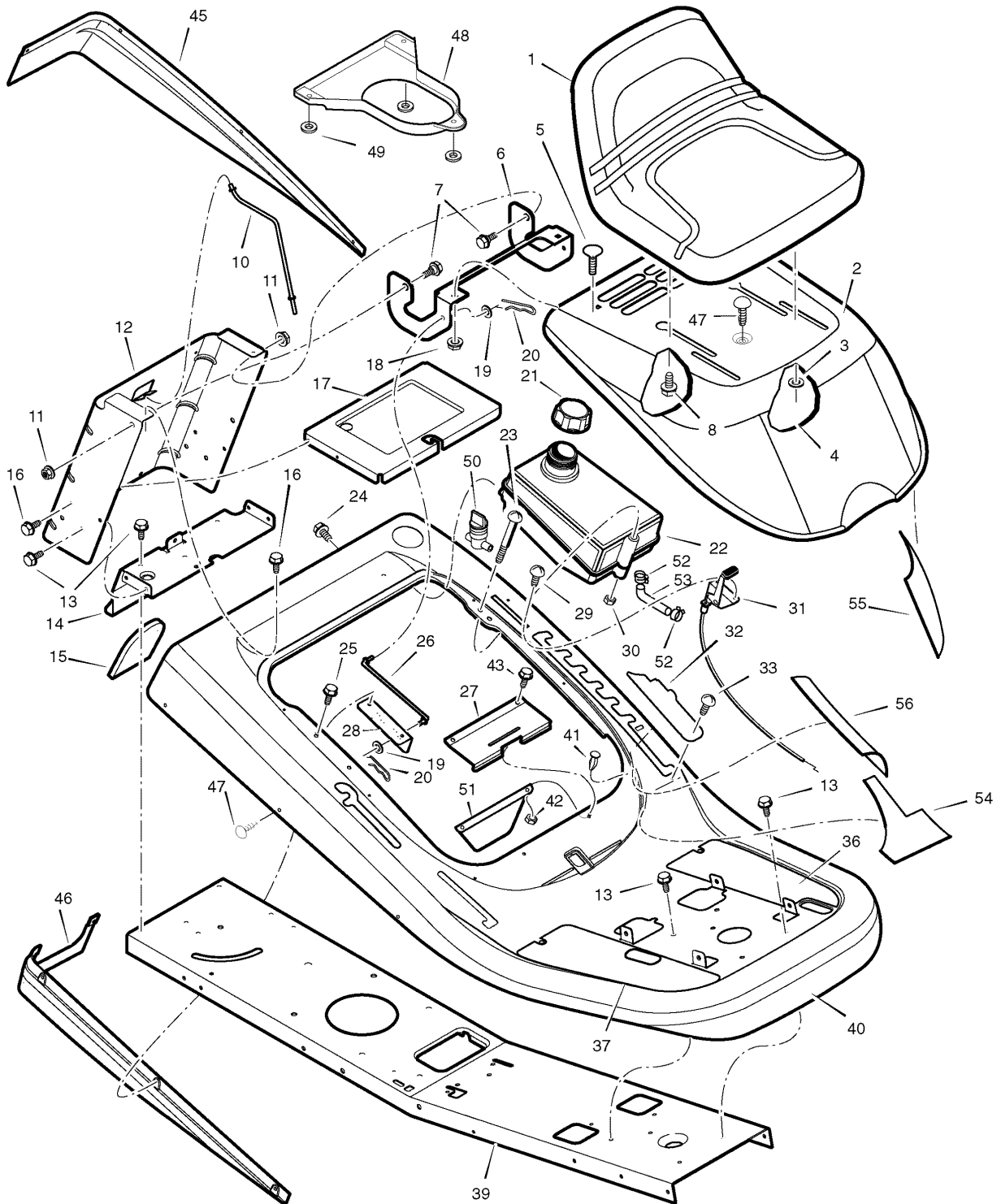

The above parts group applies to the following Mfg. Nos.:
309029x11E - 10/30, Heritage Tractor (2007)

Chassis & Hood

REF NO	PART NO.	DESCRIPTION
49	MU15X123MA	Nut, Hex 5/16-18
50	MU698183	Valve, Fuel Shutoff
51	MU1401401MA	Shield, Heat
52	MU095197MA	Hose, Clamp
53	MU1401346E701MA	Fuel, Hose
54	MU1401385MA	Heat Shield, Hood
55	MU1401208MA	Reflector Tape, Heat Shield Hood
56	MU1401209MA	Reflector Tape, Heat Shield Upper
--	MU1401361	Bag, Parts
--	111-1179	Book, Instruction
--	111-1012	Manual, Parts List

Footnotes

The above parts group applies to the following Mfg. Nos.:

309029x11E - 10/30, Heritage Tractor (2007)

Steering

0007

NOTE: Unless noted otherwise, use the standard hardware torque specification chart.

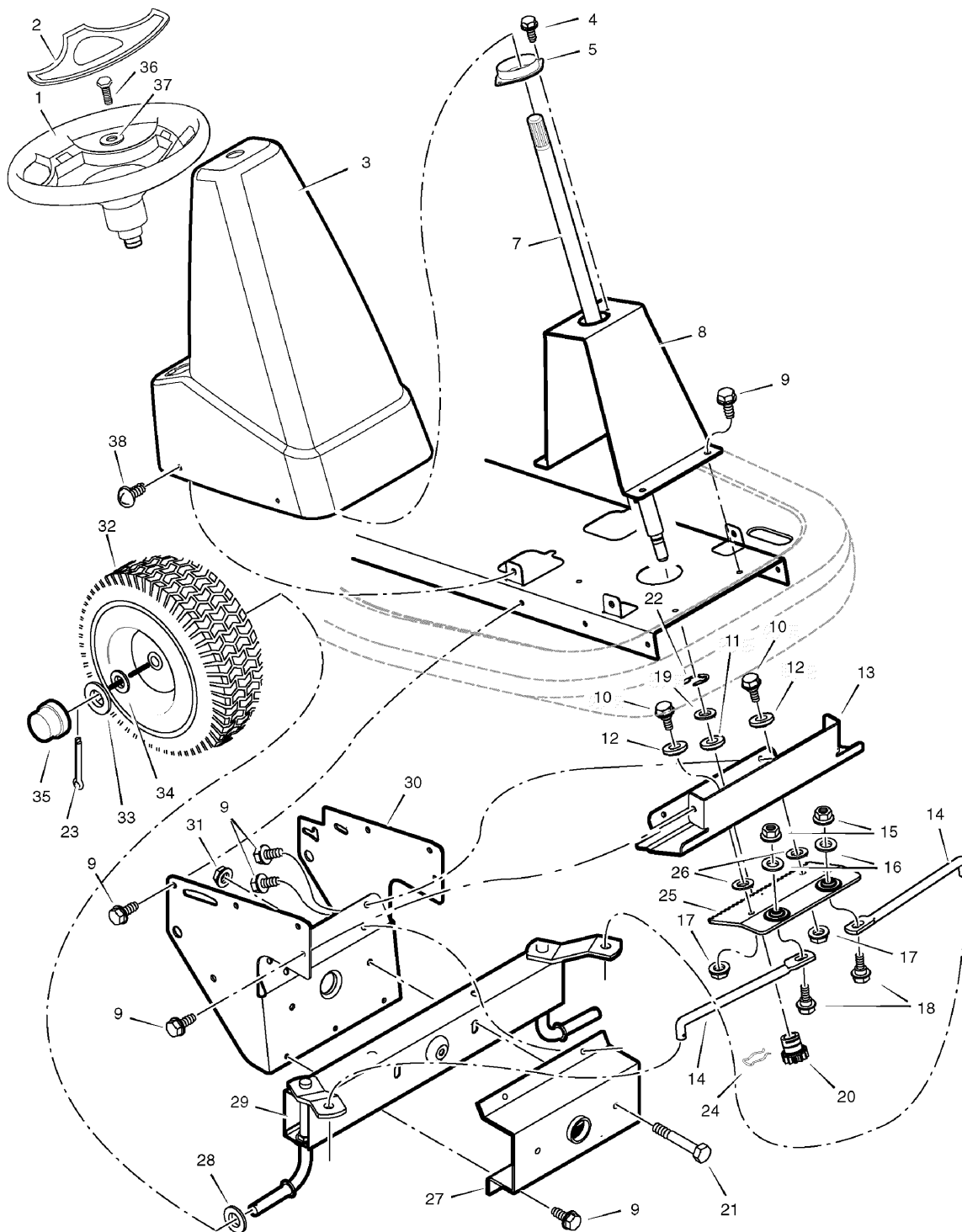

The above parts group applies to the following Mfg. Nos.:
309029x11E - 10/30, Heritage Tractor (2007)

Steering

REF NO	PART NO.	DESCRIPTION
1	MU1001980MA	Wheel, Steering
2	MU1001982MA	Cap, Steering
3	MU1401067MA	Console, High -Black
4	MU26X250MA	Screw
5	MU1401090MA	Bearing, Upper Steering
7	MU1401100MA	Shaft, Steering
8	MU1401055E701MA	Support, Steering
9	MU26X249MA	Screw
10	MU009X67MA	Bolt, Shoulder
11	MU1401098MA	Bearing, Lower Steering
12	MU1401102MA	Roller
13	MU1401058E701MA	Plate, Gear Mounting
14	MU1401123E701MA	Link, Drag
15	MU015X84MA	Nut, Flange
16	MU17X104MA	Washer
17	MU015X88MA	Nut, Flange
18	MU01X111MA	Bolt, Hex
19	MU17X118ZMA	Washer
20	MU1401099MA	Gear, Pinion
21	MU01X146MA	Bolt, Hex
22	MU011X23MA	E-Ring, Retainer
23	MU030X35MA	Pin, Cotter
24	MU094131MA	Retainer, Spring
25	MU1401046E701MA	Rack, Steering
26	MU17X201MA	Washer
27	MU1401376E701MA	Bracket, Axle Front
28	MU17X157MA	Washer
29	MU1401250E701MA	Axle & Spindle Assembly
30	MU1401059E701MA	Bracket, Support
31	MU15X118MA	Nut, Flange
32	MU1401381601MA	Wheel, Front
33	MU17X197MA	Washer
34	MU17X157MA	Washer
35	MU094618MA	Cap, Hub
36	MU0025X3MA	Bolt
37	MU17X146MA	Washer
38	MU26x270MA	Screw

Footnotes

The above parts group applies to the following Mfg. Nos.:

309029x11E - 10/30, Heritage Tractor (2007)

Motion Drive

NOTE: Unless noted otherwise, use the standard hardware torque specification chart.

0005

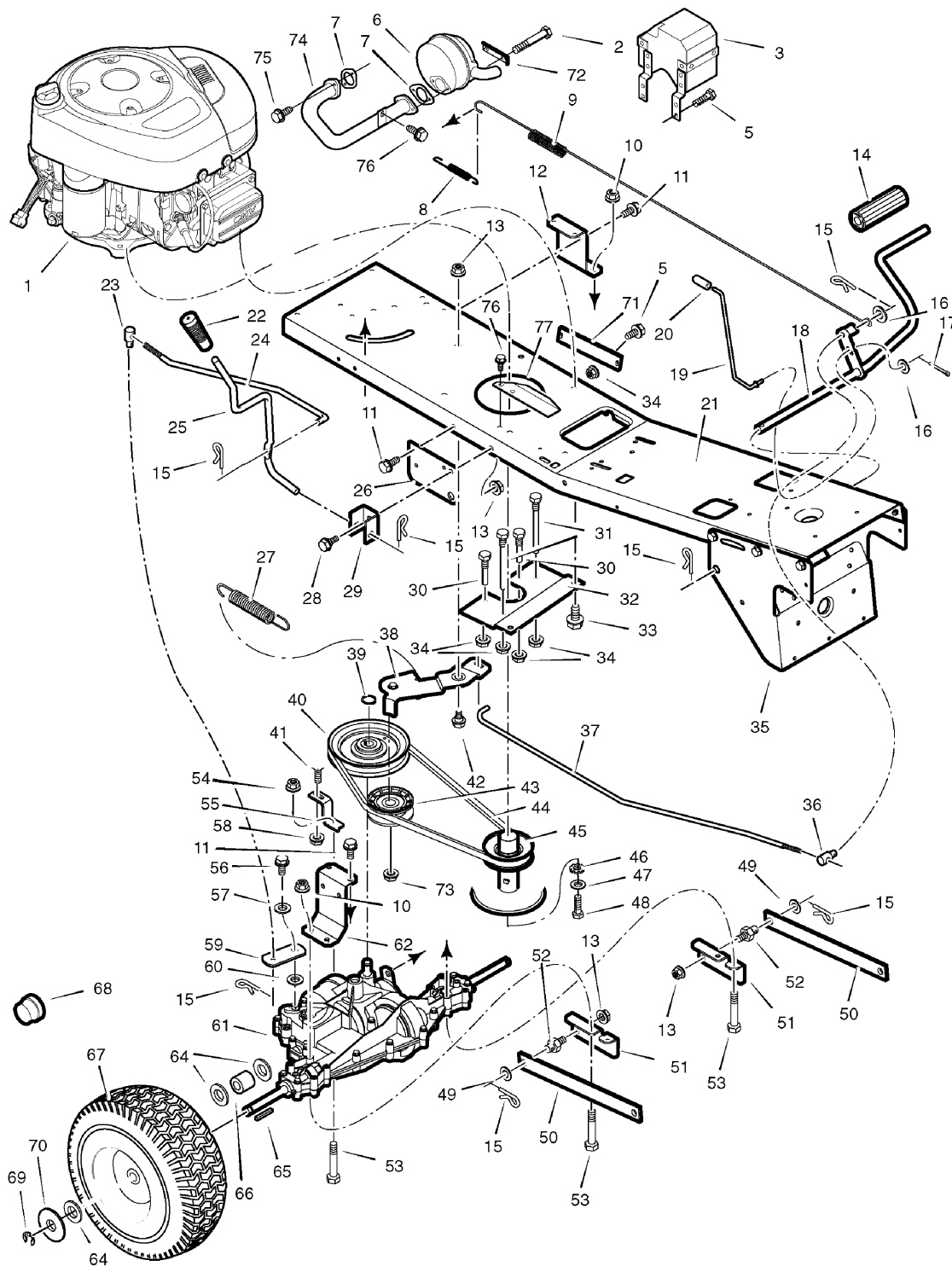

The above parts group applies to the following Mfg. Nos.:
309029x11E - 10/30, Heritage Tractor (2007)

Motion Drive

REF NO	PART NO.	DESCRIPTION
1	----	* Engine, Briggs & Stratton (2158070331E1)
2	MU01X134MA	Bolt, Hex
3	MU1401375MA	Shield Assembly, Heat
5	MU0025X2MA	Screw
6	MU1401358MA	Muffler
7	MU692236	Gasket, Muffler
8	MU165X75MA	Spring, Extension
9	MU165X148MA	Spring, Extension
10	MU015X88MA	Nut
11	MU26X249MA	Screw
12	MU1401268E701MA	Bracket, Left Transaxle
13	MU015X84MA	Nut, Flange
14	MU021544MA	Cover, Pedal
15	MU030X20MA	Pin, Cotter
16	MU017X53MA	Washer
17	MU030X20MA	Pin, Cotter
18	MU1401127E701MA	Pedal Assembly
19	MU1401112MA	Rod, Parking Brake
20	MU091079MA	Grip, Parking Brake Rod
21	MU1401371E701MA	Frame
22	MU092697MA	Grip, Shift Lever
23	MU1401148ZMA	Nut, Adjusting
24	MU1401122MA	Link, Shift
25	MU1401111MA	Lever, Shift
26	MU1401032E701MA	Bracket, Lift Pivot
27	MU165X147MA	Spring, Extension
28	MU009X39MA	Bolt, Shoulder
29	MU1401043E701MA	Bracket, Pivot
30	MU1401104MA	Guide, Belt -Short
31	MU1401105MA	Guide, Belt -Long
32	MU1401057E701MA	Plate, Belt Guide
33	MU0025X7MA	Bolt
34	MU015X79MA	Nut, Flange
35	MU1401059E701MA	Bracket, Support
36	MU094815ZMA	Nut, Adjusting
37	MU1401078MA	Rod, Clutch
38	MU1401128E701MA	Clutch Arm Assembly
39	MU0011X7MA	Ring, Retainer
40	MU1401077MA	Pulley, Drive
41	MU002X53MA	Bolt, Carriage
42	MU009X39MA	Bolt, Shoulder
43	MU1401252MA	Pulley, Idler
44	MU37X110MA	Belt, Motion Drive
45	MU1401066MA	Pulley, Split Stack

Footnotes

NOTE* For information on Replacement Parts for this engine contact the manufacturer.

NOTE** For information on Replacement Parts for this transaxle contact the manufacturer.

The above parts group applies to the following Mfg. Nos.:

309029x11E - 10/30, Heritage Tractor (2007)

Motion Drive

NOTE: Unless noted otherwise,
use the standard hardware torque
specification chart.

0005

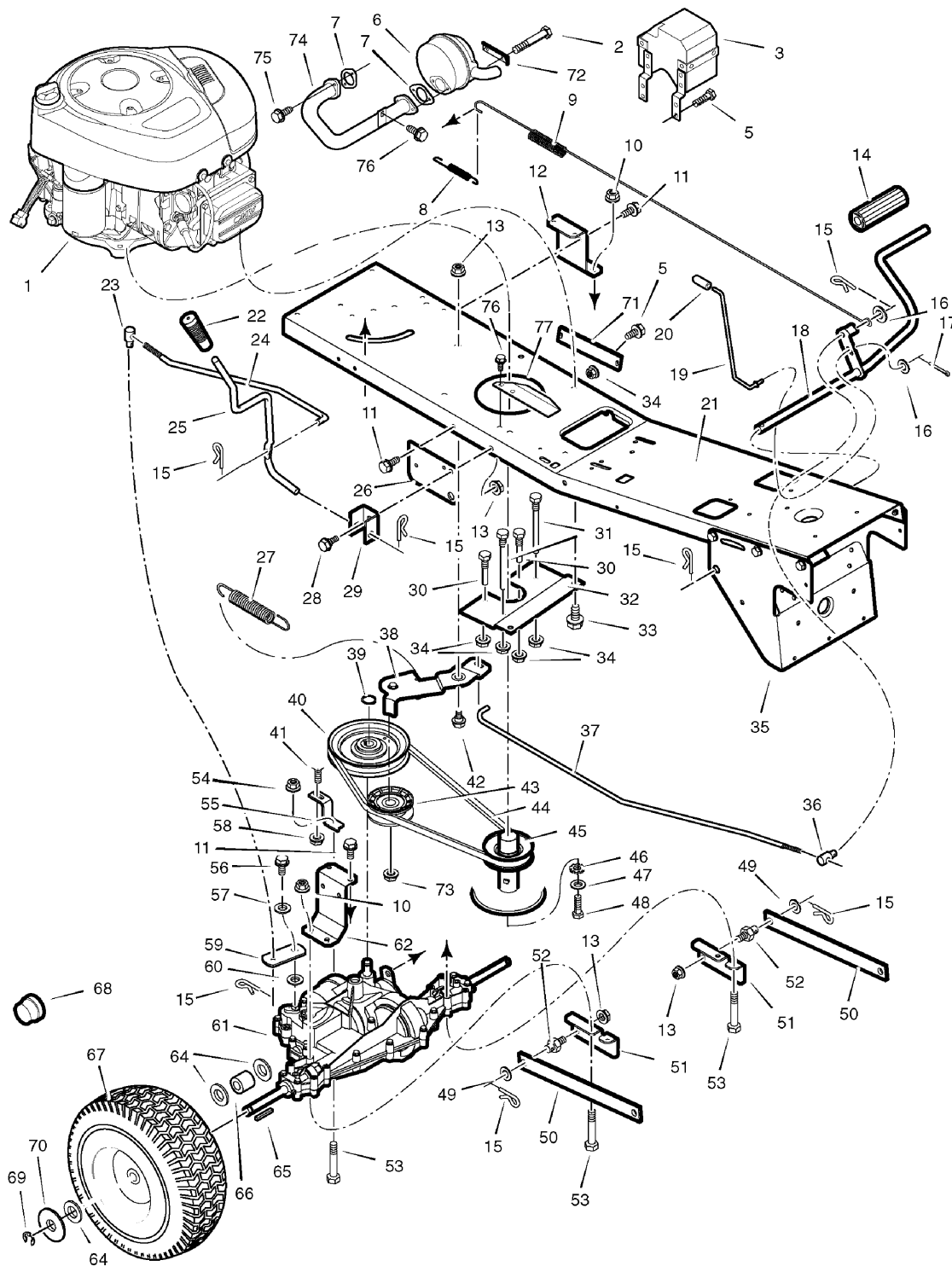

The above parts group applies to the following Mfg. Nos.:
309029x11E - 10/30, Heritage Tractor (2007)

Motion Drive

REF NO	PART NO.	DESCRIPTION
46	MU019X35MA	Washer, Star
47	MU17X170MA	Washer
48	MU01X140MA	Bolt, Hex
49	MU17X102MA	Washer
50	MU1401031E701MA	Arm, Rear
51	MU1401039E701MA	Bracket, Rear Hanger
52	MU094067MA	Pin, Threaded Shoulder
53	MU01X155MA	Bolt, Hex
54	MU01X120MA	Bolt
55	MU1401051E701MA	Bracket, Torque Reactor
56	MU06X105MA	Screw
57	MU017x38MA	Washer, Shift Yoke
58	MU015X43MA	Nut
59	MU1401351ZMA	Yoke, Shift
60	MU17X148MA	Washer
61	-----	** Transaxle, Peerless
62	MU1401042E701MA	Bracket, Right Transaxle
64	MU17X160MA	Washer
65	MU056534MA	Key, Square
66	MU1401103MA	Spacer, Rear Wheel
67	MU1401120MA	Wheel, Rear -15"
68	MU094618MA	Cap, Hub
69	MU0011X3MA	E-Ring
70	MU17X195MA	Washer
71	MU1401260E701MA	Plate, Reinforcement
72	MU092378MA	Lock, Screw
73	MU015X43MA	Nut
74	MU1401357MA	Tube, Exhaust
75	MU06x103MA	Screw
76	MU26x263MA	Screw
77	MU1401396MA	Shield, Heat

Footnotes

NOTE* For information on Replacement Parts for this engine contact the manufacturer.

NOTE** For information on Replacement Parts for this transaxle contact the manufacturer.

The above parts group applies to the following Mfg. Nos.:

309029x11E - 10/30, Heritage Tractor (2007)

Mower Housing

0011

NOTE: Unless noted otherwise,
use the standard hardware torque
specification chart.

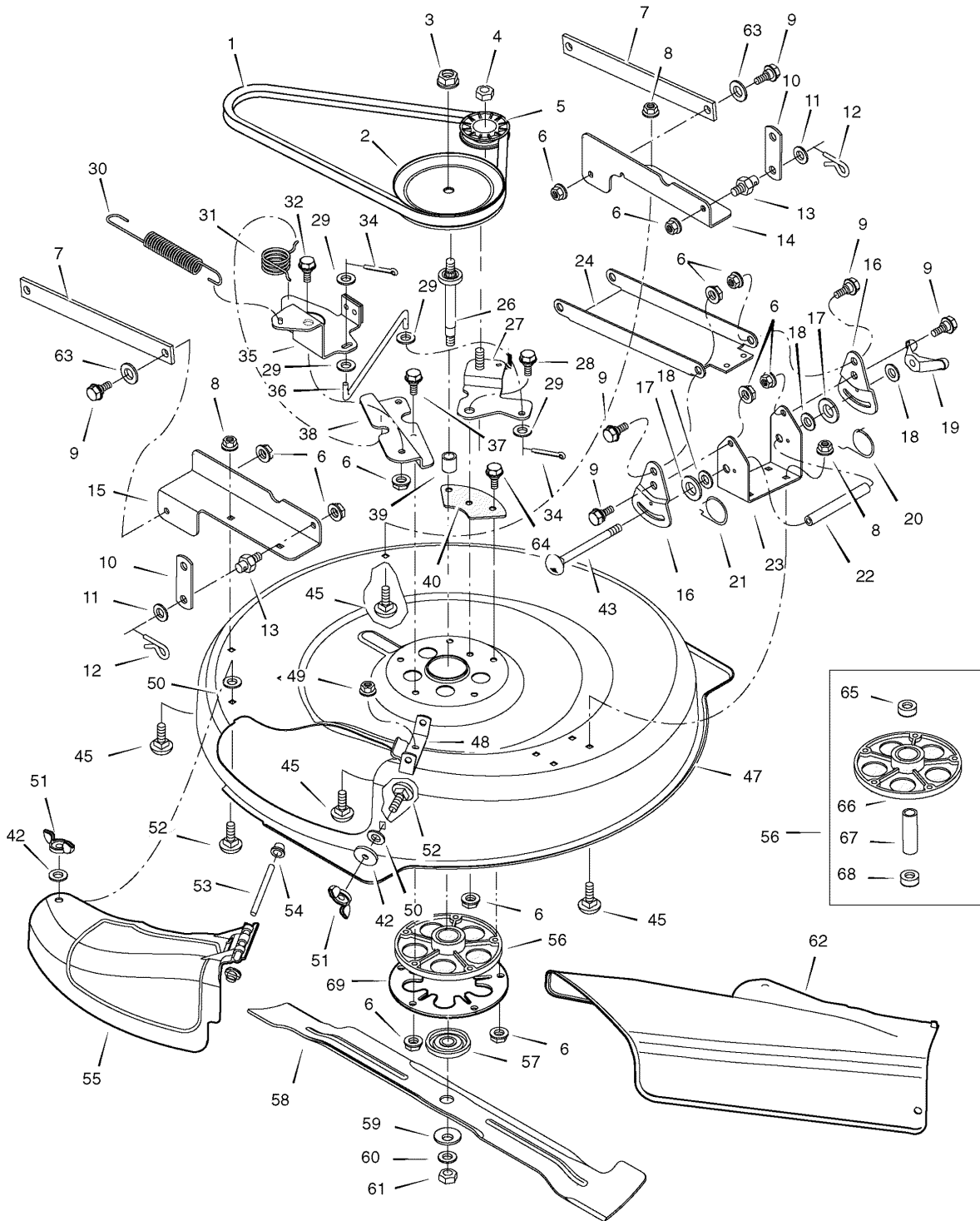

The above parts group applies to the following Mfg. Nos.:
309029x11E - 10/30, Heritage Tractor (2007)

Mower Housing

REF NO	PART NO.	DESCRIPTION
1	MU37X111MA	Belt, Blade Drive
2	MU1401092MA	Pulley, Input
3	MU15X140MA	Locknut
4	MU015X98MA	Nut, Flange
5	MU1401252MA	Pulley, Idler
6	MU015X84MA	Nut, Flange
7	MU1401031E701MA	Arm, Rear
8	MU015X79MA	Nut, Flange
9	MU009X58MA	Bolt, Shoulder
10	MU1401033E701MA	Link, Lift
11	MU17X102MA	Washer
12	MU0031X4MA	Pin, Hair
13	MU094067MA	Pin, Threaded Shoulder
14	MU1401047E701MA	Bracket, Left Rear
15	MU1401235E701MA	Bracket, Right Rear
16	MU1401038E701MA	Plate, Adjustment
17	MU094137MA	Pad, Friction
18	MU017X45MA	Washer
19	MU095004MA	Wingnut
20	MU166X43MA	Spring, Left Torsion
21	MU166X42MA	Spring, Right Torsion
22	MU1401095MA	Tube, Spacer
23	MU1401037E701MA	Bracket, Deck
24	MU1401040E701MA	Hanger, Front
26	MU1401065MA	Shaft, Splined
27	MU1401258E701MA	Arm Assembly, Idler
28	MU009X39MA	Bolt, Shoulder
29	MU017X47MA	Washer
30	MU165X157MA	Spring, Extension
31	MU166X46MA	Spring, Torsion
32	MU009X42MA	Bolt, Shoulder
34	MU030X20MA	Pin, Cotter
35	MU1401185E701MA	Arm Assembly, Brake
36	MU1401119MA	Link, Idler Arm
37	MU0025X7MA	Bolt
38	MU1401052E701MA	Bracket, Brake Mounting
39	MU1401094MA	Spacer, Jackshaft
40	MU1401259ZMA	Plate, Idler Mounting
42	MU019X45MA	Washer
43	MU002X94MA	Bolt, Carriage
45	MU002X53MA	Bolt, Carriage
47	MU1401028E701MA	Housing, Blade
48	MU1401106E701MA	Hinge, Mulching Cover
49	MU015X88MA	Nut, Flange

Footnotes

The above parts group applies to the following Mfg. Nos.:

309029x11E - 10/30, Heritage Tractor (2007)

Mower Housing

0011

NOTE: Unless noted otherwise,
use the standard hardware torque
specification chart.

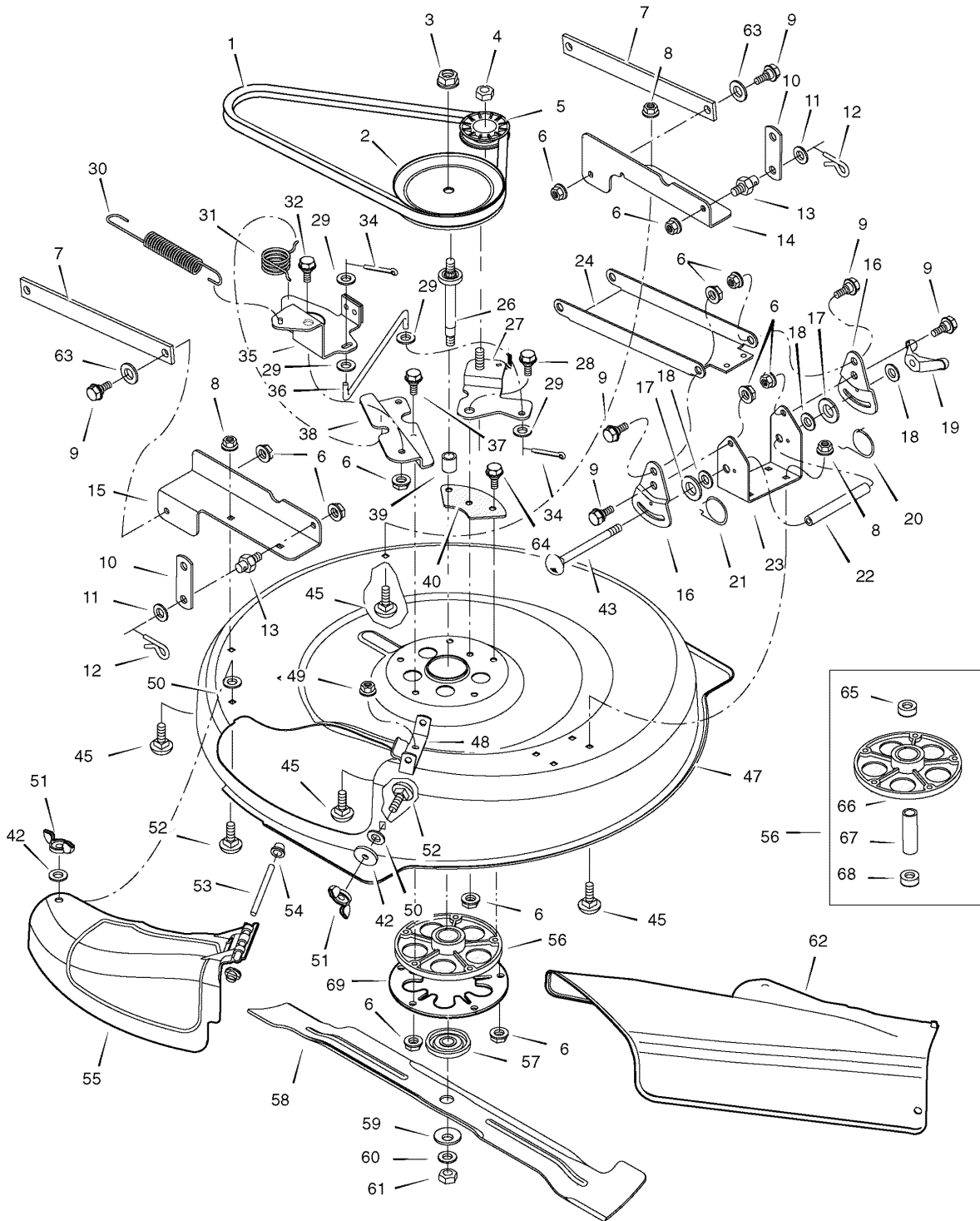

The above parts group applies to the following Mfg. Nos.:
309029x11E - 10/30, Heritage Tractor (2007)

Mower Housing

REF NO	PART NO.	DESCRIPTION
50	MU028X76MA	Nut, Speed
51	MU014X86MA	Wingnut
52	MU002X74MA	Bolt, Carriage
53	MU091767ZMA	Rod, Chute Deflector
54	MU028X23MA	Cap, Push
55	MU1401080MA	Cover, Mulch
56	MU094305MA	Mandrel Housing
57	MU1001035MA	Adapter, Blade
58	MU1401079E701MA	Blade
59	MU17X166MA	Washer, Cup
60	MU17X165MA	Washer
61	MU15X100MA	Nut, Blade Mount
62	MU1401081MA	Deflector, Chute
63	MU17X120MA	Washer
64	MU001X84MA	Bolt
65	MU092281MA	Bearing, Upper Jackshaft
66	MU94282MA	Jackshaft, Housing
67	MU090904MA	Bearing, Spacer
68	MU092282MA	Bearing, Lower Jackshaft
69	MU1001952E701MA	Plate, Jackshaft Support

Footnotes

The above parts group applies to the following Mfg. Nos.:

309029x11E - 10/30, Heritage Tractor (2007)

Mower Housing Suspension

0009

NOTE: Unless noted otherwise,
use the standard hardware torque
specification chart.

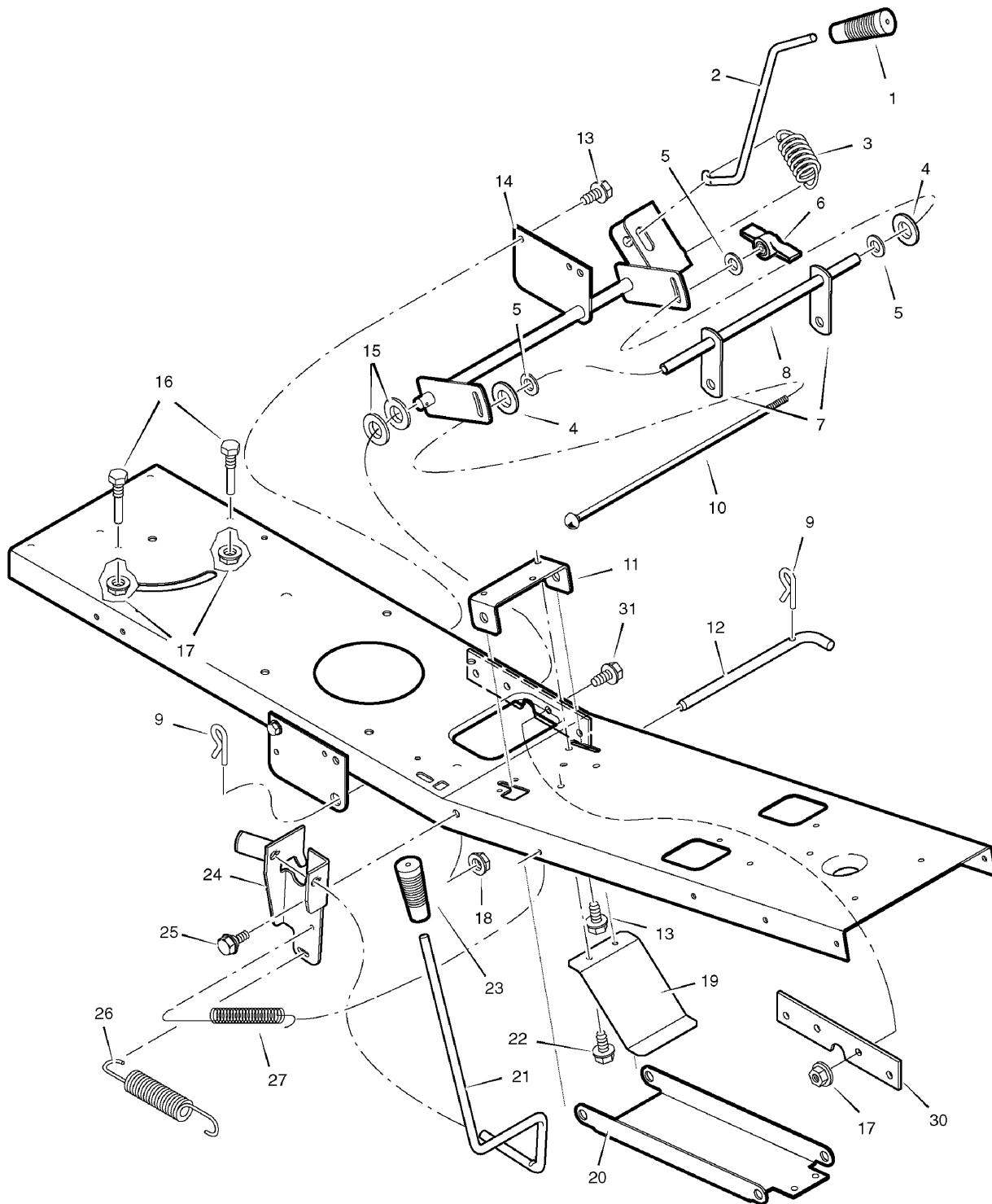

The above parts group applies to the following Mfg. Nos.:
309029x11E - 10/30, Heritage Tractor (2007)

Mower Housing Suspension

REF NO	PART NO.	DESCRIPTION
1	MU092697MA	Grip, Lift Lever
2	MU1401117MA	Lever, Lift
3	MU165X154MA	Spring, Extension
4	MU094137MA	Pad, Friction
5	MU017X45MA	Washer
6	MU095004MA	Wingnut
7	MU1401033E701MA	Link, Lift
8	MU1401096MA	Tube, Spacer
9	MU0031X4MA	Pin, Hair
10	MU002X93MA	Bolt, Carriage
11	MU1401030E701MA	Bracket, Front Hanger Pivot
12	MU1401118MA	Pin, Front Hanger
13	MU26X249MA	Screw
14	MU1401129E701MA	Arm Assembly, Lifter
15	MU17X206MA	Washer
16	MU093349MA	Screw, Guide
17	MU015X79MA	Nut, Flange
18	MU015X84MA	Nut, Flange
19	MU1401147MA	Spring, Leaf
20	MU1401040E701MA	Hanger, Front
21	MU1401116MA	Lever, PTO
22	MU26X263MA	Screw
23	MU094198MA	Grip, PTO
24	MU1401369E701MA	Bracket, PTO
25	MU009X42MA	Bolt, Shoulder
26	MU165X157MA	Spring, Extension
27	MU165X92MA	Spring, Extension
30	MU1401260E701MA	Plate, Reinforcement
31	MU26X267MA	Screw

Footnotes

The above parts group applies to the following Mfg. Nos.:

309029x11E - 10/30, Heritage Tractor (2007)

Decals

REF NO	PART NO.		DESCRIPTION
1	MU48X724MA	1	DECAL, Engagement
2	MU48X4033MA	1	DECAL, Cut Finger Symbols
3	410087	1	DECAL, Hayter Emblem
4	111-1138	1	DECAL, M10/30
5	MU48X4032MA	1	DECAL, Warning, Export
6	MU48X727MA	1	DECAL, Height Adjust, 6 Positions
7	MU48X4034MA	1	DECAL, No Step, Export
8	MU48X726MA	1	DECAL, Park Brake Symbol
9	MU48X728MA	1	DECAL, Throttle Control
10	MU48X736MA	1	DECAL, Clutch/Brake XPT
11	MU48X729MA	1	DECAL, Gas Gauge
12	MU44X5936MA	1	DECAL, Heat Shield Warning
13	MU48X511MA	1	DECAL, Warning Load Limit, Export
14	MU44X6828MA	1	DECAL, Warning Pinch Point
15	MU44X7027MA	1	DECAL, Deck Level
16	MU48X5223MA	1	DECAL, Gear Select, 5 Speed
17	111-1137	2	DECAL, Hayter Heritage
18	MU48X5911MA	1	DECAL, 100db, Export

Footnotes

The above parts group applies to the following Mfg. Nos.:

309029x11E - 10/30, Heritage Tractor (2007)

Electrical System

0013

NOTE: Unless noted otherwise, use the standard hardware torque specification chart.

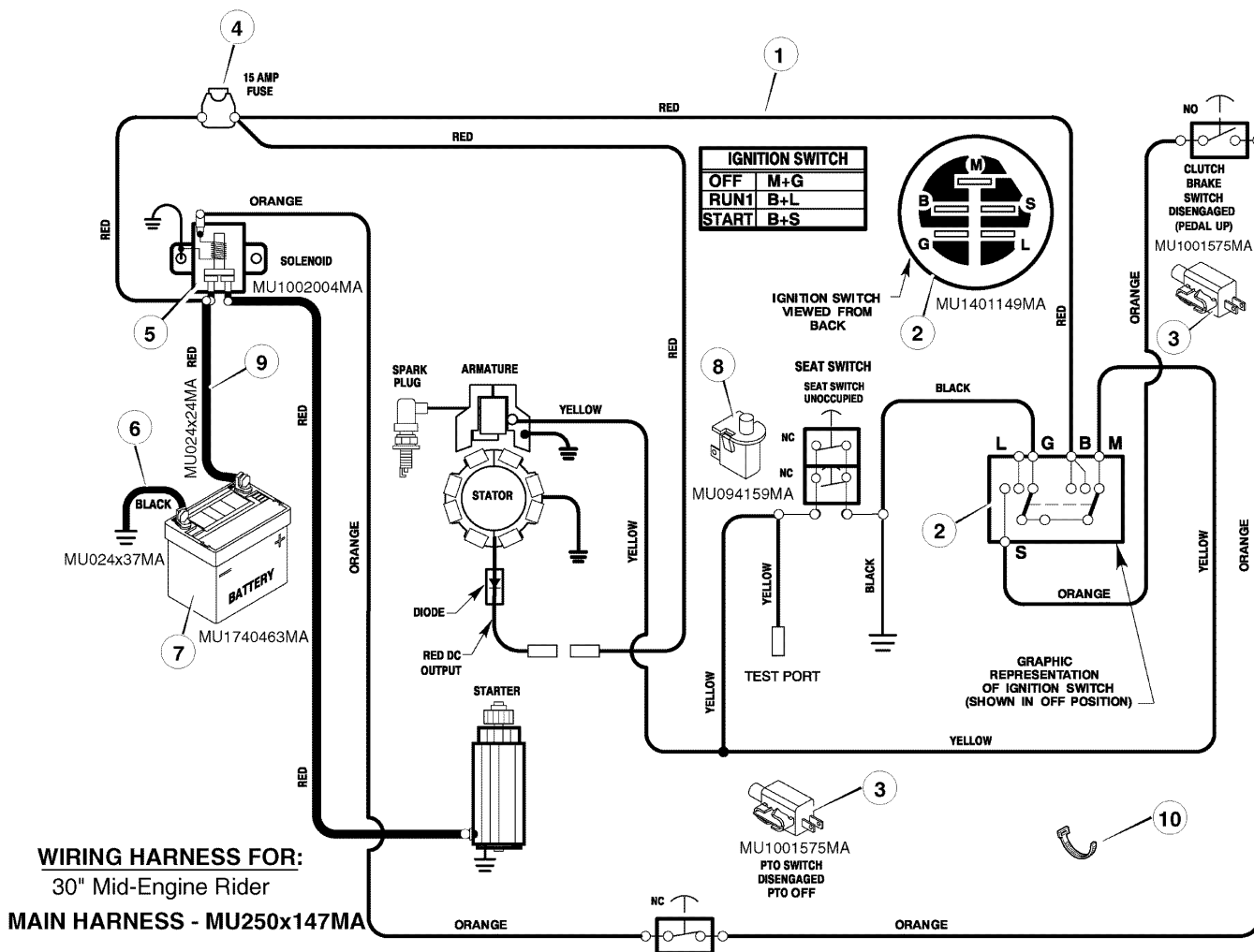

The above parts group applies to the following Mfg. Nos.:
309029x11E - 10/30, Heritage Tractor (2007)

Electrical System

REF NO	PART NO.	DESCRIPTION
1	MU250X147MA	Harness, Chassis Wire
2	MU1401149MA	Switch, Ignition
--	MU327349MA	Key, Ignition
3	MU1001575MA	Switch, Limit
4	MU054212MA	Fuse
--	MU407078MA	Holder, Fuse
5	MU1002004MA	Solenoid
--	MU26X229MA	Screw, Mounting
--	MU15X116MA	Locknut
6	MU024X37MA	Cable, Battery Ground
7	MU1740463MA	Battery
--	MU002X82MA	Bolt, Carriage
--	MU014X79MA	Wingnut
8	MU094159MA	Switch, Seat Sensor
9	MU024X24MA	Cable, Red Battery
--	MU690604MA	Boot, Positive Terminal
10	MU032618MA	Strap, Tie

Footnotes

The above parts group applies to the following Mfg. Nos.:

309029x11E - 10/30, Heritage Tractor (2007)

Hardware Identification & Torque Specifications

Common Hardware Types

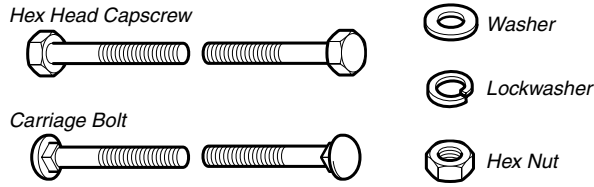

Standard Hardware Sizing

When a washer or nut is identified as 1/2", this is the *Nominal size*, meaning the *inside diameter* is 1/2 inch; if a second number is present it represents the *threads per inch*

When bolt or capscrew is identified as 1/2 - 16 x 2", this means the *Nominal size*, or *body diameter* is 1/2 inch; the second number represents the *threads per inch* (16 in this example, and the final number is the *body length* of the bolt or screw (in this example 2 inches long).

The guides and ruler furnished below are designed to help you select the appropriate hardware and tools.

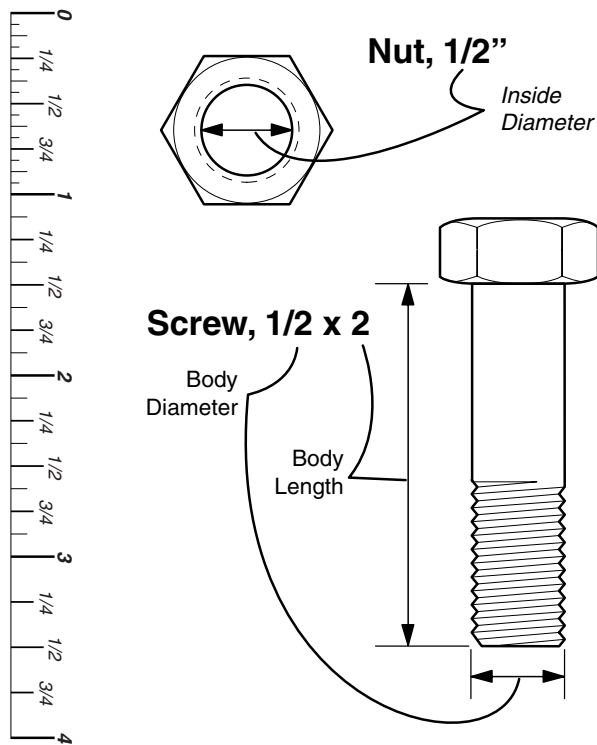

Torque Specification Chart						
FOR STANDARD MACHINE HARDWARE (Tolerance ± 20%)						
Hardware Grade	No Marks SAE Grade 2		SAE Grade 5		SAE Grade 8	
	in/lbs ft/lbs	Nm.	in/lbs ft/lbs	Nm.	in/lbs ft/lbs	Nm.
8-32	19	2.1	30	3.4	41	4.6
8-36	20	2.3	31	3.5	43	4.9
10-24	27	3.1	43	4.9	60	6.8
10-32	31	3.5	49	5.5	68	7.7
1/4-20	66	7.6	8	10.9	12	16.3
1/4-28	76	8.6	10	13.6	14	19.0
5/16-18	11	15.0	17	23.1	25	34.0
5/16-24	12	16.3	19	25.8	27	34.0
3/8-16	20	27.2	30	40.8	45	61.2
3/8-24	23	31.3	35	47.6	50	68.0
7/16-14	30	40.8	50	68.0	70	95.2
7/16-20	35	47.6	55	74.8	80	108.8
1/2-13	50	68.0	75	102.0	110	149.6
1/2-20	55	74.8	90	122.4	120	163.2
9/16-12	65	88.4	110	149.6	150	204.0
9/16-18	75	102.0	120	163.2	170	231.2
5/8-11	90	122.4	150	204.0	220	299.2
5/8-18	100	136	180	244.8	240	326.4
3/4-10	160	217.6	260	353.6	386	525.0
3/4-16	180	244.8	300	408.0	420	571.2
7/8-9	140	190.4	400	544.0	600	816.0
7/8-14	155	210.8	440	598.4	660	897.6
1-8	220	299.2	580	788.8	900	1,244.0
1-12	240	326.4	640	870.4	1,000	1,360.0

NOTES

- These torque values are to be used for all hardware excluding: locknuts, self-tapping screws, thread forming screws, sheet metal screws and socket head setscrews.
- Recommended seating torque values for locknuts:
 - for prevailing torque locknuts - use 65% of grade 5 torques.
 - for flange whizlock nuts and screws - use 135% of grade 5 torques.
- Unless otherwise noted on assembly drawings, all torque values must meet this specification.

Wrench & Fastener Size Guide



1/4" Bolt or Nut
Wrench—7/16"

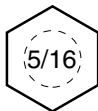

5/16" Bolt or Nut
Wrench—1/2"

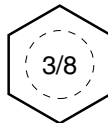

3/8" Bolt or Nut
Wrench—9/16"



7/16" Bolt or Nut
Wrench (Bolt)—5/8"
Wrench (Nut)—11/16"

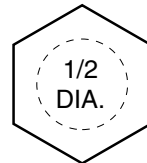

1/2" Bolt or Nut
Wrench—3/4"

